

Jaw crushers DCJ and DCD

CRUSHING



Jaw crusher DCD 4706 arranged in the treatment line for granite crushing

PSP Engineering supplies jaw crushers that are used mainly for primary crushing of all kinds of aggregate and ore, and building materials such as reinforced concrete, building

debris, bricks and asphalt blocks. The jaw crushers are produced according to the type and capacity size ranging from several tons to more than 1000 t/h.

Jaw crushers are advantageous for their excellent operating properties:

- High operating reliability
- Easily replaceable spare parts
- Low operating and maintenance cost
- Exceptional degree of comminution
- Low specific energy consumption
- High capacity
- Ideal geometry of the crushing space
- Rugged design

PSP Engineering manufactures the following versions of jaw crushers:

- **Single-toggle jaw crushers DCJ**
DCJ provides a higher degree of comminution, better shape value of grains, lower weight, smaller dimensions.
- **Double-toggle jaw crushers DCD**
DCD is able to crush extremely hard and abrasive materials.
- **Slot adjustment**
The slot is adjusted by adjusting shims that eliminate the jaw crusher wear. Adjustment is easy by means of hydraulic cylinders with a hand-operated pump. Some selected types are fitted with a comfort hydraulically controlled adjusting wedges.



The frame is rugged and well-welded together as one unit or if the crusher is bigger, it consists of several parts bolted together.

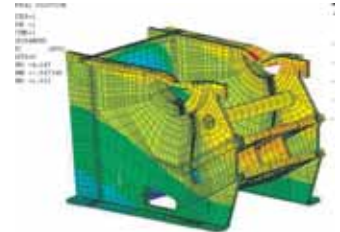

Computer analysis of a jaw crusher

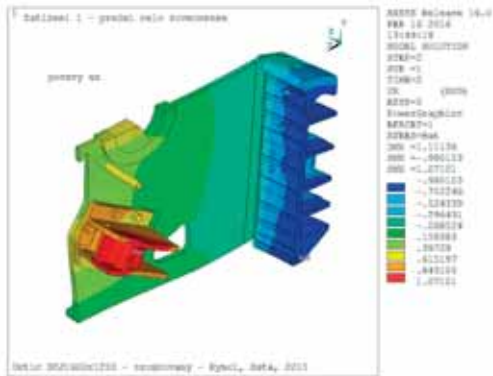

Toggle plates

Toggle plates are of a rolling design with a long service life that do not need lubricating, and are non-polluting.

Protection device

Protection device protects the shaft, bearings, pendulum or bed against damage if non-crushable piece occurs in the crushing chamber. It consists of:

- Breaking plate
- Safety coupling in flywheels.

When non-crushable piece gets into the crushing chamber, the safety coupling arms are released therefore stopping the pendulum while flywheels rotate freely on the shaft. No parts must be replaced and re-assembly takes just several minutes.

Integrated drive

There are several types of drives integrated in the frame of the crusher saving space and extending the service life of V-belts available.



Jaw crushers DCJ and DCD

Large-diameter shafts are made of a treated chrome-vanadium forged pieces. Automatic lubrication is available.

Armors or jaws with bigger crushers are made of more parts. Worn parts can be exchanged without using a heavy crane.

High-percentage manganese jaws are reversible, which extends their service life.

Flexible seating of crushers on rubber springs decreases the forces on foundations significantly.

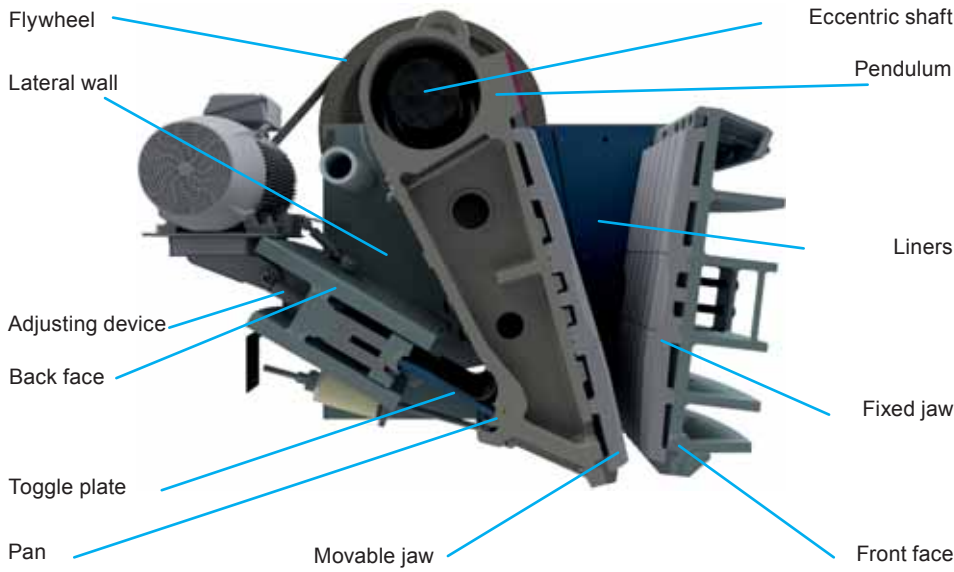

CRUSHING



Jaw crusher DCJ 1031 on the track mounted crushing unit

Grain size composition of the product

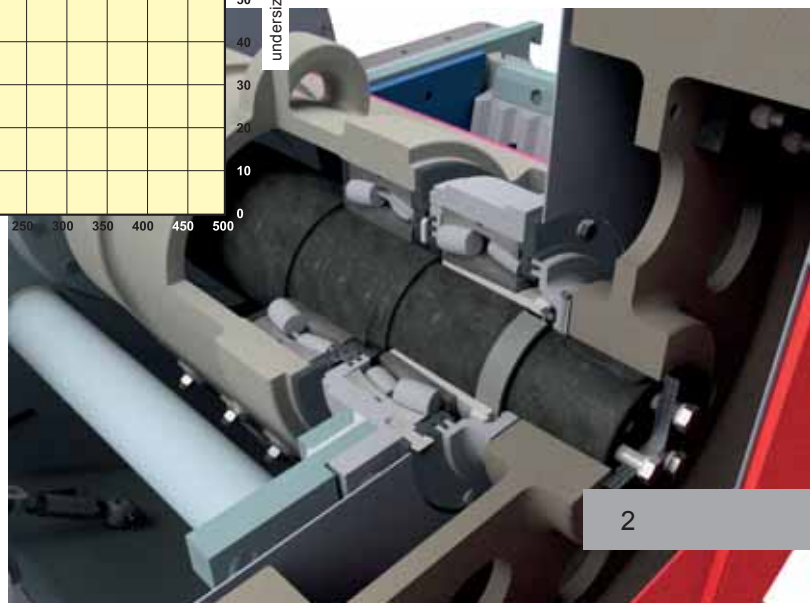
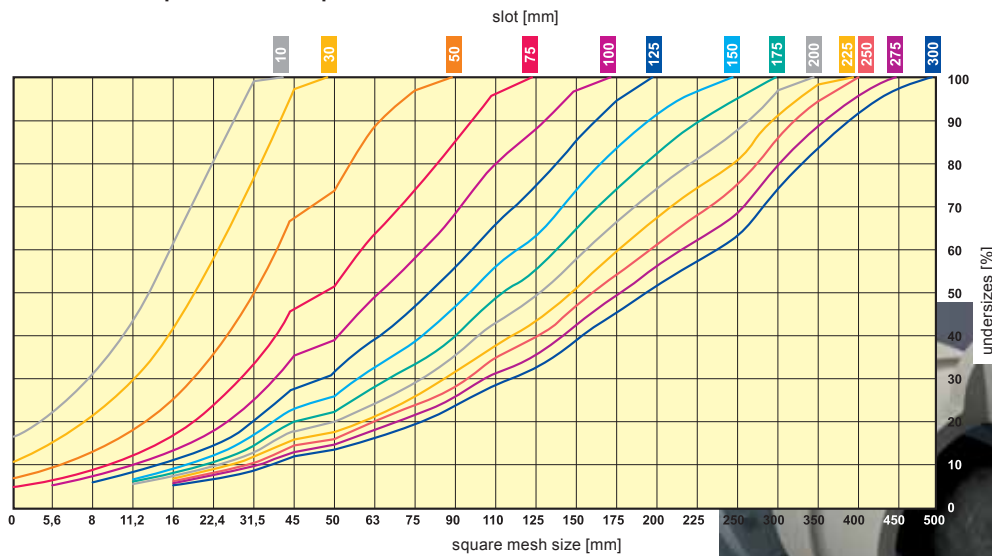

Jaw crushers DCJ and DCD

CRUSHING



Jaw crusher DCJ 1100x800 – granite crushing



Jaw crusher DCJ 1200x1000 – granite crushing



Jaw crusher DCJ 1400x1120 – limestone crushing

PSP Engineering supplies jaw crushers DCJ or DCD, built-in mobile or semi-mobile units positioned on a steel structure, or as single machines.

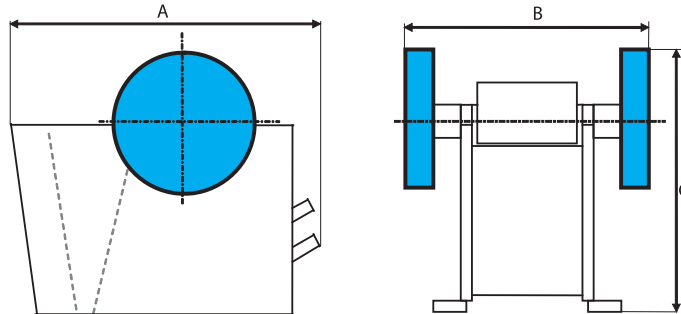

Main dimensions

Type	Inlet opening mm	A mm	B mm	C mm
1032	500x300	1430	1170	1270
1033	700x300	1767	1420	1540
1033	700x500	1767	1420	1540
1023	900x500	1938	1741	1630
1031	900x600	2069	1775	1775
1039	1100x700	2525	2350	2280
1021	1100x800	2650	2430	2660
1022	1200x800	2931	2364	2620
1028	1200x1000	3400	2842	3104
1029	1400x1120	3790	3050	3613
1038	1600x1250	4070	3860	4950
1025	2000x1500	5113	4097	4519

Type	Inlet opening mm	Setting mm	Capacity t/h	Power input kW
1032	500x300	20 - 70	16 - 60	30
1033	700x300	15 - 50	18 - 60	45
1033	700x500	30 - 110	37 - 140	45
1023	900x500	30 - 185	45 - 300	55
1031	900x600	40 - 170	65 - 285	75
1039	1100x700	50 - 180	105 - 395	90
1021	1100x800	63 - 200	140 - 460	110
1022	1200x800	63 - 200	140 - 530	132
1028	1200x1000	85 - 230	200 - 580	132
1029	1400x1120	100 - 250	275 - 730	160
1038	1600x1250	120 - 300	500 - 990	200
1025	2000x1500	170 - 350	600 - 1300	250

The minimum permitted slot size depends on the hardness and toughness of the crushed material and it must be consulted with a producer. Stated capacities are only informative and depend on properties and composition of the crushed material.

Jaw crushers DCJ and DCD

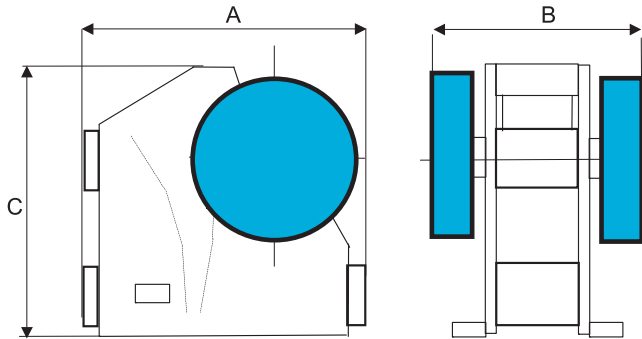

Main dimensions of jaw crushers DCD

Type	Inlet opening mm	A mm	B mm	C mm
DCD 4701	500x400 (540x400R)	1680	1100	1325
DCD 4702	630x500 (700x500R)	2070	1420	1610
DCD 4703	800x630	3095	1920	2235
DCD 4709	1000x700R	3195	2155	2715
DCD 4704	1000x800	3900	2650	2680
DCD 4775	1100x800R	3165	2095	2510
DCD 4705	1250x1000	4680	2890	3615
DCD 4706	1600x1250	5440	3555	4082
DCD 4707	2000x1600	6750	4365	4730

Main technical parameters of jaw crushers DCD

Type	Inlet opening mm	Setting mm	Capacity t/h	Power input kW
DCD 4701	500x400	30 - 80	25 - 65	30
DCD 4701	540x400R	10 - 60	9 - 55	30
DCD 4702	630x500	30 - 80	30 - 85	40
DCD 4702	700x500R	10 - 60	12 - 70	40
DCD 4703	800x630	60 - 150	95 - 245	75
DCD 4709	1000x700R	50 - 130	105 - 290	55
DCD 4704	1000x800	100 - 180	200 - 375	90
DCD 4775	1100x800R	50 - 200	100 - 415	75
DCD 4705	1250x1000	130 - 250	300 - 600	132
DCD 4706	1600x1250	150 - 300	405 - 860	160
DCD 4707	2000x1600	200 - 400	630 - 1350	250

The minimum permitted slot size depends on the hardness and toughness of the crushed material and it must be consulted with a producer. Stated capacities are only informative and depend on properties and composition of the crushed material.



Container crushing unit with the crusher DCJ 1033

CRUSHING



Jaw crusher DCD 1600x1250 – granodiorite crushing



Jaw crusher V9-2N – olivite crushing



Jaw crusher V10-2N – gabbro crushing