

# Cone crushers KDC

## CRUSHING

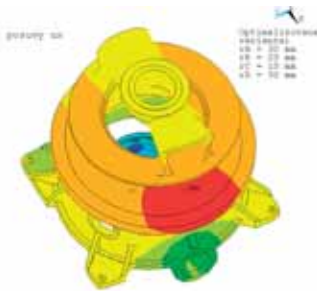

Cone crushers KDC 32 JP - gravel crushing



Cone crusher KDC model - solid body



Computing analysis of a cone with the shaft for the cone crusher KDC. Stress in the solid model.



Cone crusher assembly

PSP Engineering continuously completes and innovates the line of compact cone crushers KDC. We pay a great attention to shapes of crushing areas because these are of the main influence on quality of the crushed stone, output parameters as well as on optimum load of single components of the crusher. This is the way how to attain longer service life of spare parts, reduce operation costs, shorten time necessary for maintenance and save energy.

The capacity of crushers KDC ranges from several ten to more than 800 tons of crushed material per hour. Each crusher size can be supplied in several variants varying in dimensions of the inlet opening. The crushers

are fitted with hydraulic system that allows effortless adjustment of the outlet setting and easy discharge of the crushing space after congestion and protects the machine against damage from overloading or if a non-crushable piece passes through.

Hydraulic cone crushers KDC are used for secondary and tertiary crushing of hard, abrasive, non-sticking materials with compression strength of up to 400 MPa such as quartz, granite or basalt. The crushers KDC are usually supplied with a common frame and drive seated on rubber springs in order to reduce the dynamic loads on the supporting structure underneath the crusher.

### Basic characteristics of the crusher line KDC:

- High operating reliability
- Low cost for operating and maintenance
- Rugged design
- Exceptional degree of comminution
- Easy maintenance
- Simple operation
- High variability
- Easy adjustment of the crushing setting
- Easy discharge of the crushing chamber after congestion
- Ideal geometry of the crushing chamber
- Simple integration of the crusher into automated production lines
- Remote monitoring of the operation via internet
- High quality of the final product (grain size distribution and shape value)
- Crushing elements with a high percentage of manganese
- Rugged main shaft made of chrome-vanadium steel
- Automated operation
- Bevel gear with spiral teeth

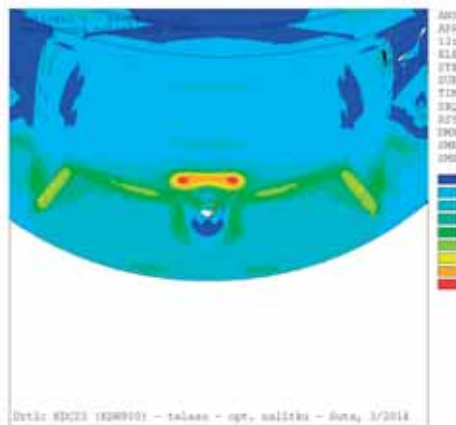

Stress analysis of new shapes for stress reduction

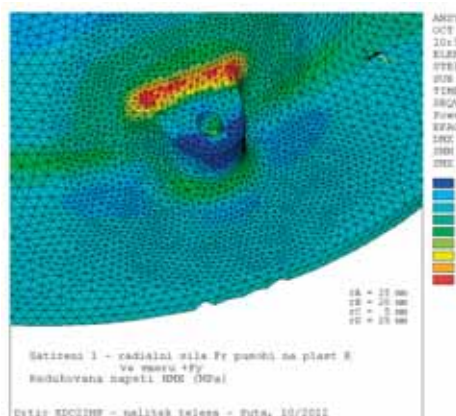

Casing body detail



Control computer display

Crushers KDC are equipped with the control system COMPACT. COMPACT simplifies the operation and allows for a maximum utilization of the crusher capacity. It is capable to change parameters on-line, increase the quality of the product and to monitor the operating parameters such as the pressure in the hydraulic circuit, power input of the drive, size of the outlet slot and temperature of lubricating oil. The control system continuously processes these parameters and optimizes the crusher operation according to its values. Possible failures are monitored and recorded.

# Cone crushers KDC

## CRUSHING

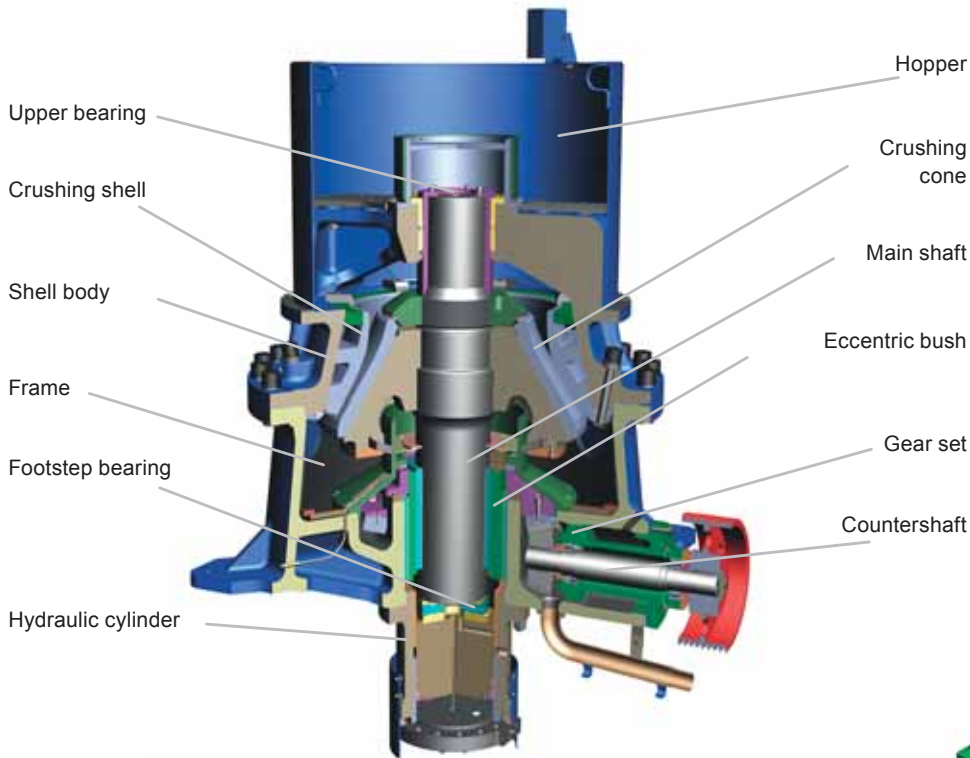

KDC 35 FP – greywacke crushing

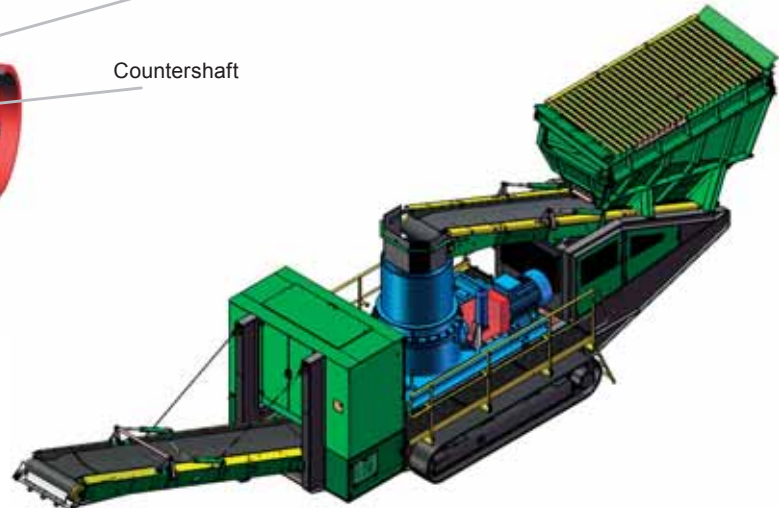

Mobile crushing station with the cone crusher KDC 33

### Grain size distribution of the product for medium crushable material

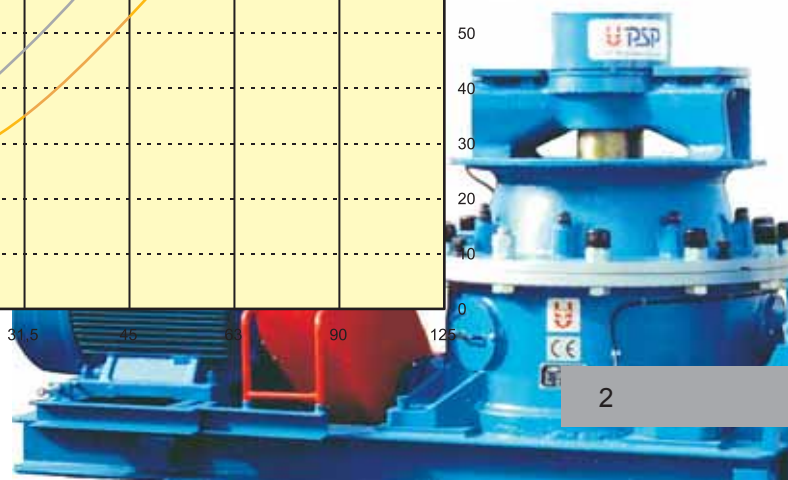
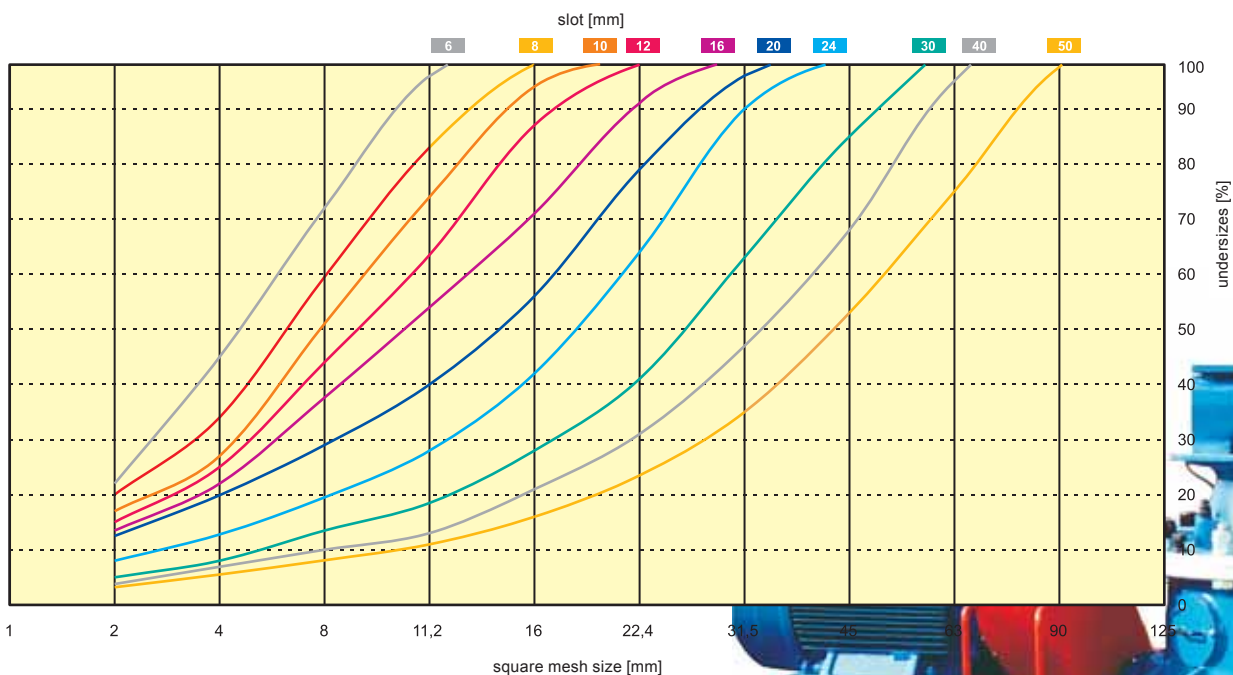

# Cone crushers KDC

## CRUSHING



Crushing chamber of the secondary crusher



Crushing chamber of the tertiary crusher



Cone crusher KDC 35 FP - greywacke crushing



Cone crusher KDC 36 GP – basalt crushing

### Constant crushing space of the cone crusher KDC

Cone crushers KDC have advanced crushing chambers that keep the final product parameters uniform. The crushing chamber is of a curved design with the vertical area of the opening at the inlet remaining constant almost throughout the service life of crushing elements. This design maintains a constant high output level without changing the product parameters.

Crushing elements, except for the KDC 26xx and 36xx, are not grouted and can be easily and quickly exchanged. The fact that no potting is used shortens the shutdown time and lowers the dependence on climatic conditions. In case

of freezing, it is possible to exchange worn crushing elements outside the heated area. Crusher shells with big rings can be used repeatedly. The independent rings improve the seating of the crusher casing along the entire height of the casing body.

The size of inlet openings of tertiary crushers corresponds to the aggregate passing through screens of 32, 63, 90, 120 and 150 mm. The shape design of crushing chambers with secondary and tertiary crushers KDC results in a higher quality of the final product and lower operating costs by reducing wear of the crushing elements.

### Principle parameters of secondary crushers KDC

Type	Setting	Max. inlet piece*	Capacity	El. motor
	mm	mm	t/h	kW
KDC 22 HP	19 - 35	188	80 - 180	75 - 90
KDC 23 VP	25 - 50	270	135 - 300	132 - 160
KDC 23 HP	20 - 42	220	120 - 265	
KDC 24 VP	27 - 57	310	165 - 460	160 - 200
KDC 24 HP	22 - 47	250	140 - 400	
KDC 25 EP	30 - 65	430	240 - 590	200
KDC 25 VP	30 - 63	330	240 - 560	
KDC 25 HP	24 - 52	260	190 - 460	
KDC 27 VP	35 - 65	430	500 - 850	315
KDC 27 HP	25 - 55	345	360 - 760	
KDC 27 SH	22 - 50	280	310 - 660	

### Principle parameters of tertiary crushers KDC

Type	Setting	Max. inlet piece*	Capacity	El. motor
	mm	mm	t/h	kW
KDC 32 SP	10 - 25	101	45 - 120	75 - 90
KDC 32 JP	6 - 22	73	35 - 105	
KDC 32 FP	4 - 16	43	30 - 80	
KDC 33 SP	14 - 32	150	80 - 205	132
KDC 33 JP	10 - 25	115	65 - 170	
KDC 33 GP	8 - 22	80	50 - 150	
KDC 33 FP	6 - 18	45	45 - 135	160
KDC 34 SP	15 - 32	170	120 - 330	
KDC 34 JP	10 - 25	115	90 - 300	
KDC 34 GP	8 - 22	80	80 - 280	160 - 200
KDC 34 FP	6 - 18	50	65 - 230	
KDC 35 SP	18 - 42	190	160 - 420	
KDC 35 JP	12 - 32	115	130 - 340	160 - 200
KDC 35 GP	10 - 28	80	110 - 320	
KDC 35 FP	8 - 20	50	100 - 250	
KDC 37 SP	20 - 45	220	300 - 530	315
KDC 37 SJ	17 - 38	170	240 - 450	
KDC 37 JP	14 - 35	120	220 - 430	
KDC 37 GP	12 - 30	80	180 - 380	
KDC 37 FP	10 - 25	50	150 - 330	

\* Max. inlet piece is 80 – 100% of the inlet opening defined with the square mesh. Stated capacities and minimum settings are only informative and depend on properties and composition of the crushed material and way of feeding.

# Cone crushers KDC

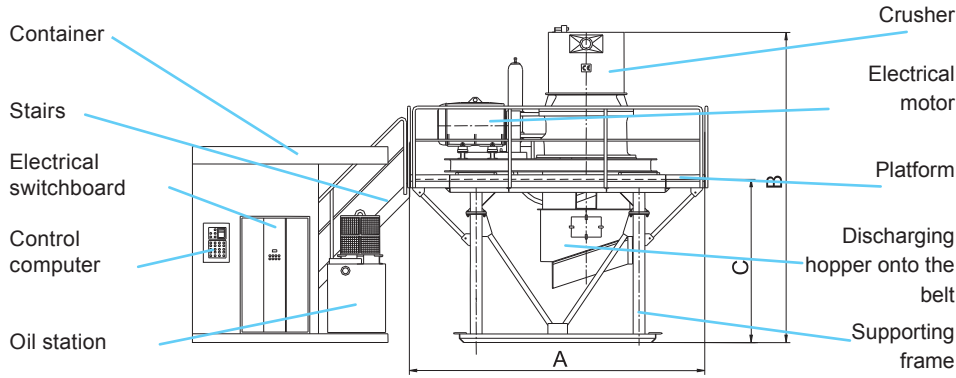

Semi-mobile steel structure on skids.

## Principle dimensions of secondary crushers KDC

Type	A mm	B mm	C mm
KDC 22xx	3300x2970	4070	2050
KDC 23xx	4280x3270	5000	2500
KDC 24xx	4710x3670	5600	2720
KDC 25 EP	4670x3940	6215	2690
KDC 25xx	4670x3940	5980	2690
KDC 27xx	4730x4530	6720	3270

## Principle dimensions of tertiary crushers KDC

Type	A mm	B mm	C mm
KDC 32xx	3300x2970	3955	2050
KDC 33xx	4280x3270	4700	2500
KDC 34xx	4710x3670	5250	2720
KDC 35xx	4670x3940	5705	2690
KDC 37xx	4730x4530	6310	3270

## CRUSHING



Cone crusher KDC 35 GP – andesite crushing



Cone crusher KDC 33 JP – spilite crushing



Cone crushers KDC 35 FP and KDC 23 HP – greywacke crushing



Tertiary crushing with crushers KDC 32 JP



Cone crusher KDC 33 FP – granite crushing



Cone crusher KDC 23 HP - slag crushing